

BOCK® HGX24 CO₂ T

Operating guide

HGX24/55-4 ML CO₂ T
 HGX24/70-4 ML CO₂ T
 HGX24/90-4 ML CO₂ T
 HGX24/110-4 ML CO₂ T

HGX24/35-4 S CO₂ T
 HGX24/55-4 S CO₂ T
 HGX24/70-4 S CO₂ T
 HGX24/90-4 S CO₂ T
 HGX24/110-4 S CO₂ T

HGX24/55-4 SH CO₂ T
 HGX24/70-4 SH CO₂ T
 HGX24/90-4 SH CO₂ T
 HGX24/110-4 SH CO₂ T

HGX24/55 MLP 6 CO₂ T
 HGX24/70 MLP 7 CO₂ T
 HGX24/90 MLP 8 CO₂ T
 HGX24/110 MLP 10 CO₂ T

HGX24/55 SP 7 CO₂ T
 HGX24/70 SP 9 CO₂ T
 HGX24/90 SP 12 CO₂ T
 HGX24/110 SP 15 CO₂ T

HGX24/55 SHP 7 CO₂ T
 HGX24/70 SHP 9 CO₂ T
 HGX24/90 SHP 12 CO₂ T
 HGX24/110 SHP 15 CO₂ T

About these instructions

Read these instructions before assembly and before using the compressor. This will avoid misunderstandings and prevent damage. Improper assembly and use of the compressor can result in serious or fatal injury.

Observe the safety instructions contained in these instructions.

These instructions must be passed onto the end customer along with the unit in which the compressor is installed.

Contents

Page

1	Safety	4
1.1	Identification of safety instructions	
1.2	Qualifications required of personnel	
1.3	Safety instructions	
1.4	Intended use	
2	Product description	6
2.1	Short description	
2.2	Name plate	
2.3	Type key	
2.4	Type key compressors with LSPM Motor (Line Start Permanent Magnet)	
3	Areas of application	8
3.1	Refrigerants	
3.2	Oil charge	
3.3	Limits of application	
4	Compressor assembly	10
4.1	Storage and transportation	
4.2	Setting up	
4.3	Connecting the pipelines - solder system	
4.4	Connecting the pipelines - cutting ring system	
4.5	Pipes	
4.6	Flange shut-off valves (HP/LP)	
4.7	Laying suction and pressure lines	
4.8	Operating the shut-off valves	
4.9	Operating mode of the lockable service connections	
4.10	Oil return	
4.11	Suction pipe filter	

GB

5	Electrical connection	15
5.1	Information for contactor and motor contactor selection	
5.2	Connection of the driving motor	
5.3	Circuit diagram for direct start 230 V Δ / 400 V Y	
5.4	Electronic trigger unit INT69 G	
5.5	Connection of the electronic trigger unit INT69 G	
5.6	Functional test of the electronic trigger unit INT69 G	
5.7	Oil sump heater	
5.8	Selection and operation of compressors with frequency converters	
6	Commissioning	20
6.1	Preparations for start-up	
6.2	Pressure strength test	
6.3	Leak test	
6.4	Evacuation	
6.5	Refrigerant charge	
6.6	Start-up	
6.7	Pressure switch	
6.8	Decompression valves	
6.9	Avoiding slugging	
6.10	Filter dryer	
7	Maintenance	24
7.1	Preparation	
7.2	Work to be carried out	
7.3	Spare parts recommendation / accessories	
7.4	Lubricants / oil	
7.5	Decommissioning	
8	Technical data	26
9	Dimensions and connections	30
10	Declaration of incorporation	32

1 | Safety

1.1 Identification of safety instructions:



DANGER

Indicates a dangerous situation which, if not avoided, will cause immediate fatal or serious injury



WARNING

Indicates a dangerous situation which, if not avoided, may cause fatal or serious injury



CAUTION

Indicates a dangerous situation which, if not avoided, may immediately cause fairly severe or minor injury.



ATTENTION

Indicates a situation which, if not avoided, may cause property damage



INFO

Important information or tips on simplifying work

GB

1.2 Qualifications required of personnel



WARNING

Inadequately qualified personnel poses the risk of accidents, the consequence being serious or fatal injury. Work on compressors must therefore only be performed by personnel with appropriate expert knowledge and the qualifications listed below:

- For example, a refrigeration technician, refrigeration mechatronics engineer. As well as professions with comparable training, which enable personnel to assemble, install, maintain and repair refrigeration and air-conditioning systems. Personnel must be capable of assessing the work to be carried out and recognising any potential dangers.

1 | Safety

1.3 Safety instructions



WARNING

Risk of accident.

Refrigerating compressors are pressurised machines and therefore require particular caution and care in handling.

The maximum permissible overpressure must not be exceeded, even for testing purposes.

Risk of burns!

- Depending on the operating conditions, surface temperatures of over 60 °C on the pressure side or below 0 °C on the suction side can be reached.
- Avoid the contact with refrigerant under any circumstances. The contact with refrigerant can lead to severe burns and skin irritations.

Danger of suffocation.

CO₂ is a nonflammable, acidic, colourless and odourless gas and heavier than air.

Never release significant volumes of CO₂ or the entire contents of the system into closed rooms!

Safety installations are designed or adjusted in accordance with EN 378-2 or appropriate safety standards.

- Therefore, we expressly point out that all information in this assembly instruction has been provided according to our current level of knowledge and may change due to further development. Legal claims based on the correctness of the information cannot be made at any time and are hereby expressly excluded.

Compressors with LSPM Motor:

When the compressor is open, there is danger from a strong magnetic field.

See also Chapter 7, Maintenance.

GB

1.4 Intended use



WARNING

The compressor may not be used in potentially explosive environments!

These assembly instructions describe the standard version of the compressors named in the title manufactured by Bock. Bock refrigerating compressors are intended for installing in a machine (within the EU according to the EU Directives 2006/42/EC Machinery Directive and 2014/68/EU Pressure Equipment Directive).

Commissioning is only permissible if the compressors have been installed in accordance with these assembly instructions and the entire system into which they are integrated has been inspected and approved in accordance with legal regulations.

The compressors are intended for use with CO₂ in transcritical and/or subcritical systems in compliance with the limits of application.

Only the refrigerant specified in these instructions may be used.

Any other use of the compressor is prohibited!

2 | Product description

2.1 Short description

- Semi-hermetic four-cylinder reciprocating compressor with suction gas cooled driving motor.
- The flow of refrigerant sucked in from the evaporator is led over the engine and provides for a particularly intensive cooling. Thus the engine can be kept on a relatively low temperature level specially during high load.
- Oil pump independent of direction of rotation for reliable and safe oil supply.
- One decompression valve each on the low and high pressure side, which vent into the atmosphere when inadmissibly high pressure levels are reached.

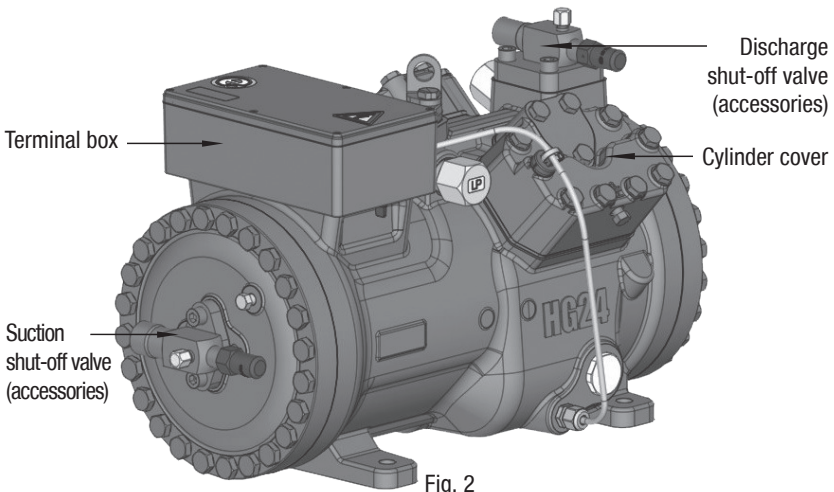
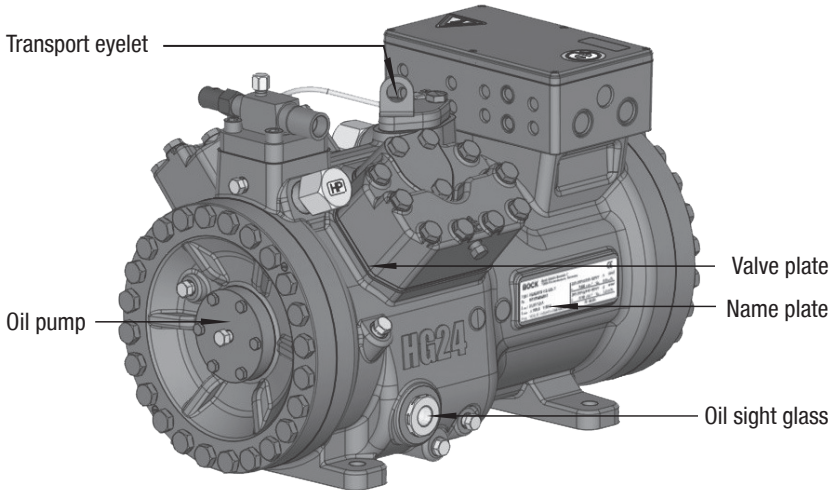

Dimension and connection values can be found in chapter 9

2 | Product description

2.2 Name plate (example)

BOCK Bock GmbH, Benzstr. 7 72636 Frickenhausen, Germany		CE	
1	Typ : HGX24/70-4 S CO ₂ T	220-240V Δ / 380-420VY -3- 50HZ	6
2	Nr . : BC12345A001	n : 1450 min ⁻¹ V _{th} : 6,0 m ³ /h	7
3	I _{max} : 31,0/17,9A	265-290V Δ / 440-480VY -3- 60HZ	8
4	I _{block} Δ : 169A Y : 98A	n : 1740 min ⁻¹ V _{th} : 7,2 m ³ /h	9
5	p _{max} : ND(LP) / HD(HP)-100/150 bar	IP66	10
		Öl : BOCKlub E85	11
			12
			13

Fig. 3

1	Type designation	6	Voltage, circuit, frequency	} 50 Hz
2	Machine number	7	Nominal rotation speed	
3	maximum operating current	8	Displacement	} 60 Hz
4	Starting current (rotor blocked)	9	Voltage, circuit, frequency	
5	ND (LP): max. admissible operating pressure (g) Low pressure side	10	Nominal rotation speed	
	HD (HP): max. admissible operating pressure (g) High pressure side	11	Displacement	
		12	Oil type filled at the factory	
		13	Terminal box protection type	

i Observe the limits of application diagrams!

i Electrical accessories can change the IP protection class!

GB

2.3 Type key (example)

HG X 24 / 110-4 S CO₂ T

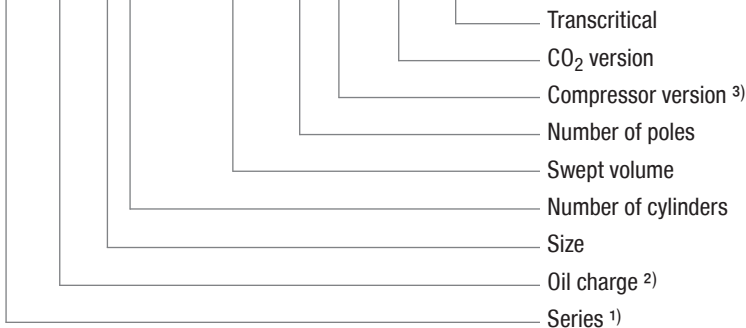

- 1) HG - Hermetic Gas-Cooled (suction gas-cooled)
- 2) X - Ester oil charge
- 3) ML - Normal cooling and deep freezing at low and medium evaporation temperatures
- S - For frequency regulation and extended limits of application
- SH - For high evaporating temperatures eg. heat pumps, different oil charge

2 | Product description

2.4 Type key compressors with LSPM Motor (example)

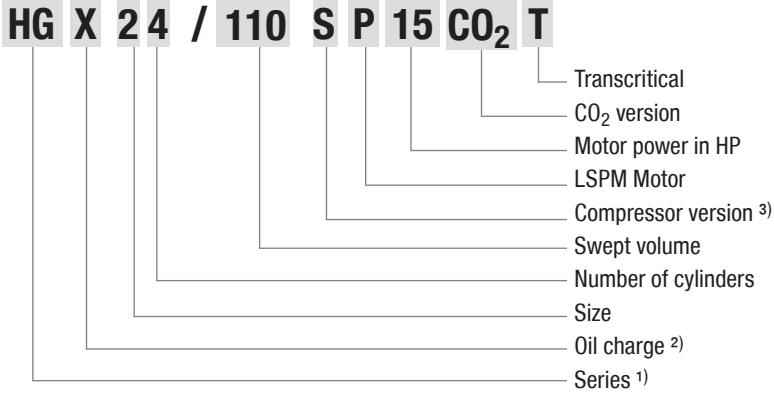

¹⁾ HG - Hermetic Gas-Cooled (suction gas-cooled)

²⁾ X - Ester oil charge

³⁾ MLP - Normal cooling and deep freezing at low and medium evaporation temperatures

SP - For frequency regulation and extended limits of application

SHP - For high evaporating temperatures eg. heat pumps, different oil charge

3 | Areas of application

3.1 Refrigerants

- R744: CO₂ (Recommendation CO₂ quality 4.5 (< 5 ppm H₂O))

3.2 Oil charge

- The compressors are filled at the factory with the following oil type:

Compressor version **ML(P)** and **S(P)**: **BOCK** lub E85

Compressor version **SH(P)**: **BOCK** C170E



ATTENTION Property damage possible.

The oil level must be in the visible part of the sight glass; damage to the compressor is possible if overfilled or underfilled!

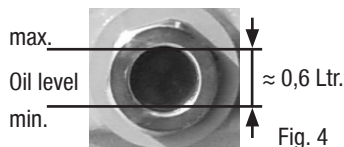

3.3 Limits of application



ATTENTION Compressor operation is possible within the operating limits. These can be found in Bock compressor selection tool (VAP) under vap.bock.de. Observe the information given there.

- Permissible ambient temperature (-20 °C) - (+60 °C).
- Max. permissible discharge end temperature 160 °C.
- Min. discharge end temperature ≥ 50 °C.
- Min. oil temperature ≥ 30 °C.
- Max. permissible switching frequency 12x /h.
- A minimum running time of 3 min. steady-state condition (continuous operation) must be achieved.

Avoid continuous operation in limit range.

Max. permissible operating pressure (LP/HP)¹⁾: 100/150 bar

¹⁾ LP = Low pressure

HP = High pressure

GB

4 | Compressor assembly



INFO

New compressors are factory-filled with inert gas. Leave this service charge in the compressor for as long as possible and prevent the ingress of air.

Immediately after refrigeration technological connection of the compressor close the shut-off devices in suction-, discharge-, oil return line etc. and evacuate the compressor. Check the compressor for transport damage before starting any work.

4.1 Storage and transportation



- Storage at (-30 °C) - (+70 °C), maximum permissible relative humidity 10 % - 95 %, no condensation.
- Do not store in a corrosive, dusty, vaporous atmosphere or in a combustible environment.



- Use transport eyelet.
- Do not lift manually!
- Use lifting gear!

GB

4.2 Setting up



ATTENTION

Attachments (e.g. pipe holders, additional units, fastening parts, etc.) directly to the compressor are not permissible!

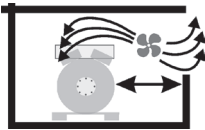

- Provide adequate clearance for maintenance work.
- Ensure adequate compressor ventilation.



- Do not use in a corrosive, dusty, damp atmosphere or a combustible environment.

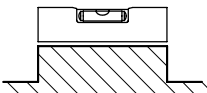

- Setup on an even surface or frame with sufficient load-bearing capacity.
- Single compressor preferably on vibration damper.
- Compound connection basically rigid.

4 | Compressor assembly

4.3 Connecting the pipelines - solder system



ATTENTION Damage possible.

Superheating can damage the valve.

Remove the pipe supports therefore from the valve for soldering and accordingly cool the valve body during and after soldering.

Only solder using inert gas to inhibit oxidation products (scale).

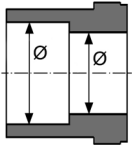

Fig. 5: graduated internal diameter

- **Material soldering / welding connection: S235 (JRG2C)**
- The **pipe connections** have graduated inside diameters so that pipes with standard millimetre and inch dimensions can be used.
- The connection diameters of the shut-off valves are rated for maximum compressor output. **The actual required pipe cross section must be matched to the output. The same applies for non-return valves.**

4.4 Connecting the pipelines - cutting ring system

- On its high-pressure side, the compressor has a shut-off valve with multi-sided cutting ring for safe installation of the discharge line.

Cutting ring function after tightening the union nut

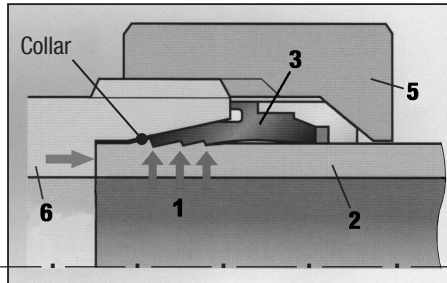

Fig. 6
Figure similar

GB

Tube preparation:

The tube has to be sawn in a right angle. An angular tolerance of $\pm 1^\circ$ is permissible.

Slightly trim the pipe ends inside and outside. For thin walled steel pipes or soft pipes made of nonferrous metal, reinforcing sleeves have to be used.

Pipe assembly:

Push union nut (5) and cutting ring (3) onto pipe (2). Insert pipe into socket (6) as far as it will go and firmly press against pipe stop, otherwise incorrect assembly. Hand tighten union nut until socket, cutting ring and union nut are locked. Tighten union nut $1 \frac{1}{2}$ turns using a spanner wrench. The cutting ring is noticeably locked to the socket face (for assembly inside pipe connection, hold up valve with a spanner wrench). This should cause the cutting ring with its cutting edges (1) to cut into the pipe resulting in a visible collar. In order to stick to the turns we recommend using marking lines on union nut and pipe. After assembly, it is necessary to check the collar. The gasket must not be damaged. At least 80 % of the cutting face has to be covered. After check-up, screw on and tighten again as described above.

4 | Compressor assembly

4.5 Pipes

- Pipes and system components must be clean and dry inside and free of scale, swarf and layers of rust and phosphate. Only use hermetically sealed parts.
- Lay pipes correctly. Suitable vibration compensators must be provided to prevent pipes being cracked and broken by severe vibrations.
- Ensure a proper oil return.
- Keep pressure losses to an absolute minimum.

4.6 Flange shut-off valves (HP/LP)



CAUTION

Risk of injury.

The compressor must be depressurized through connections A1 and B1 before commencing any work and prior to connecting to the refrigerant system.

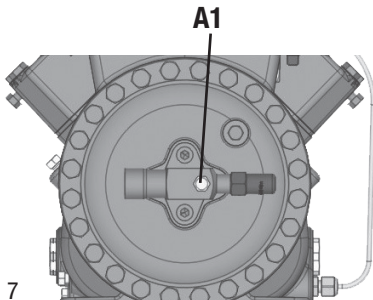

Fig. 7

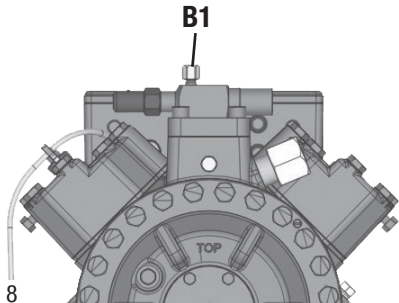

Fig. 8

GB

4 | Compressor assembly

4.7 Laying suction and pressure lines



ATTENTION Property damage possible.

Improperly installed pipes can cause cracks and tears which can result in a loss of refrigerant.



INFO

Proper layout of the suction and pressure lines directly after the compressor is integral to the smooth running and vibration behaviour of the system.

A rule of thumb: Always lay the first pipe section starting from the shut-off valve **downwards and parallel to the drive shaft**.

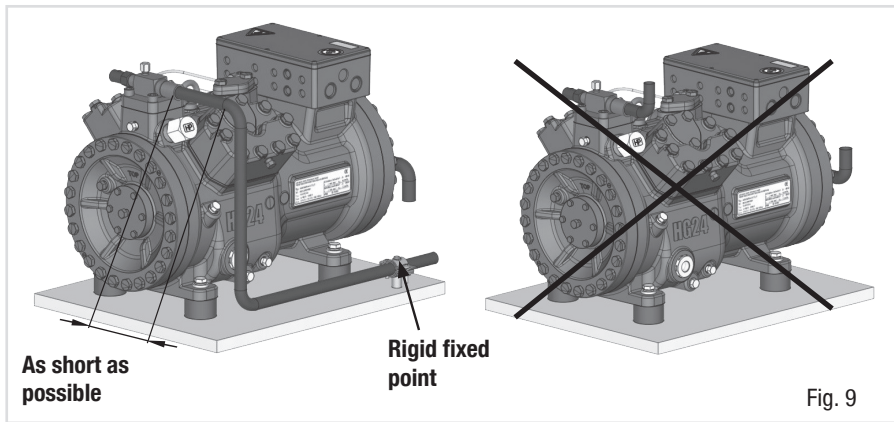

GB

4.8 Operating the shut-off valves (example)

- Before opening or closing the shut-off valve, release the valve spindle seal by approx. $\frac{1}{4}$ of a turn counter-clockwise.
- After activating the shut-off valve, re-tighten the adjustable valve spindle seal clockwise.

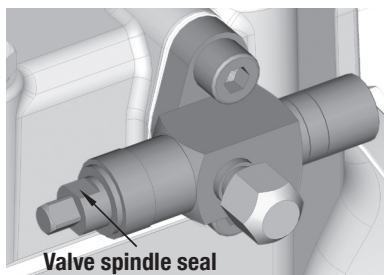

Fig. 10

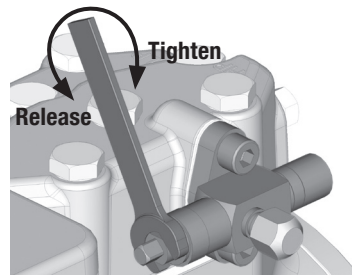
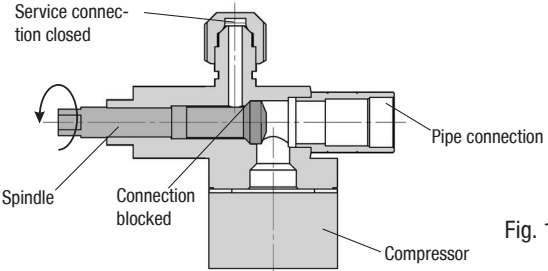

Fig. 11

4 | Compressor assembly

4.9 Operating mode of the lockable service connections



Opening the shut-off valve:
Spindle: turn to the left (counter-clockwise) as far as it will go.
—> Shut-off valve completely opened / service connection closed.

Fig. 12

GB

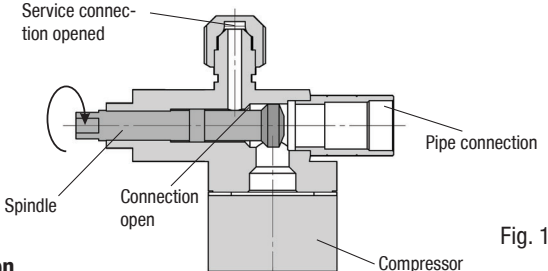

Opening the service connection
Spindle: Turn 1/2 - 1 turn to the right clockwise.
—> Service connection opened / shut-off valve opened.

Fig. 13

After activating the spindle, generally fit the spindle protection cap again and tighten with 40 - 50 Nm. This serves as a second sealing feature during operation.

4.10 Oil return

To ensure the oil return function will work reliably no matter what kind of system configuration you are using, Bock recommends incorporating oil separators or oil level monitoring equipment. The "O" connection is already available from the factory for the purpose of installing the additional oil level monitoring component. Oil should be returned from the oil separator to the compressor via the "D1" connection provided for this purpose on the compressor.

4.11 Suction pipe filter

For systems with long pipes and higher degree of contamination, a filter on the suction-side is recommended. The filter has to be renewed depending on the degree of contamination (reduced pressure loss).

5 | Electrical connection

5 Electrical connection



DANGER

Risk of electric shock! High voltage!
Only carry out work when the electrical system is disconnected from the power supply!



ATTENTION

When attaching accessories with an electrical cable, a minimum bending radius of 3 x the cable diameter must be maintained for laying the cable.



INFO

Connect the compressor motor in accordance with the circuit diagram (see inside of terminal box).

- Use suitable cable glands of the correct protection type (see name plate) for routing cables into the terminal box. Insert the strain reliefs and prevent chafe marks on the cables.
- Compare the voltage and frequency values with the data for the mains power supply.

Only connect the motor if these values are the same.

5.1 Information for contactor and motor contactor selection

All protection equipment, switching and monitoring devices must comply with the local safety regulations and established specifications (e.g. VDE) as well as the manufacturer's specifications. **Motor protection switches are required!** Motor contactors, feed lines, fuses and motor protection switches must be rated according to the maximum operating current (see name plate). For motor protection, use a current-dependent, time-delayed overload protection device for monitoring all three phases. Adjust the overload protection device so that it must be actuated within 2 hours at 1.2 times the maximum working current.

For compressors with LSPM motor, a faster responding overload protection device is recommended.

5.2 Connection of the driving motor

The compressor is designed with a motor for star-delta circuits.

Designation on the name plate Δ / Y

Star-delta start-up is only possible on 230 V voltage supply. Example:

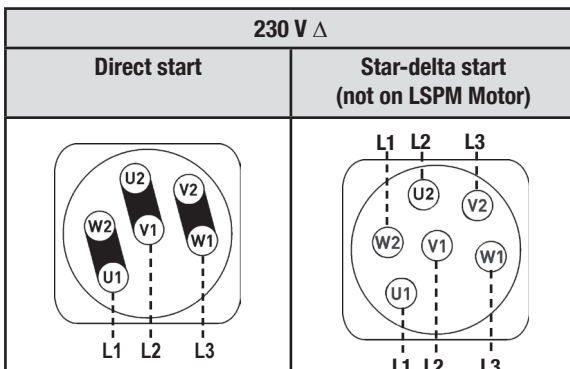

INFO

The connection examples shown refer to the standard version. In the case of special voltages, the instructions affixed to the terminal box apply.

Only direct start is possible with LSPM Motor.

5.3 Circuit diagramm for direct start 230 V Δ / 400 V Y

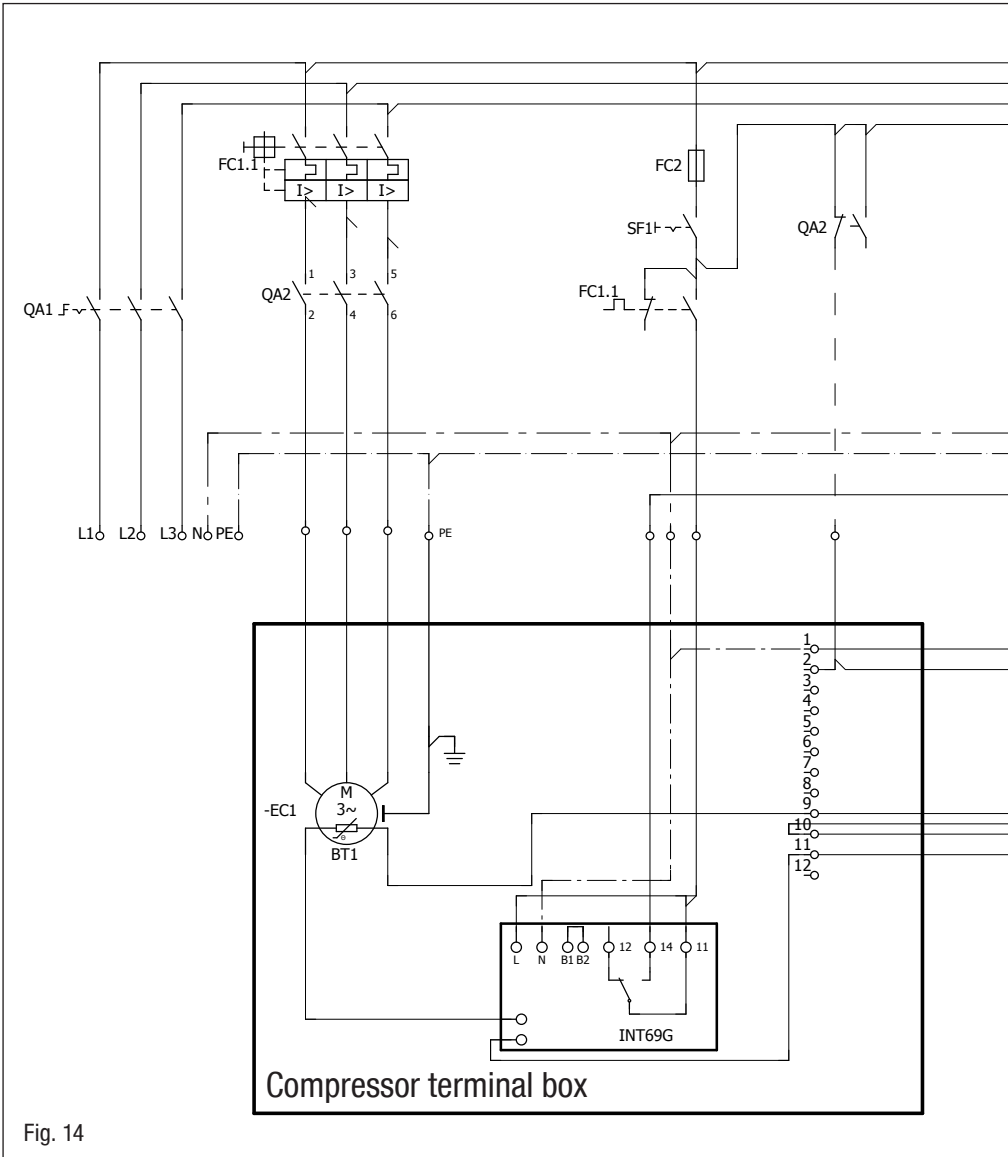
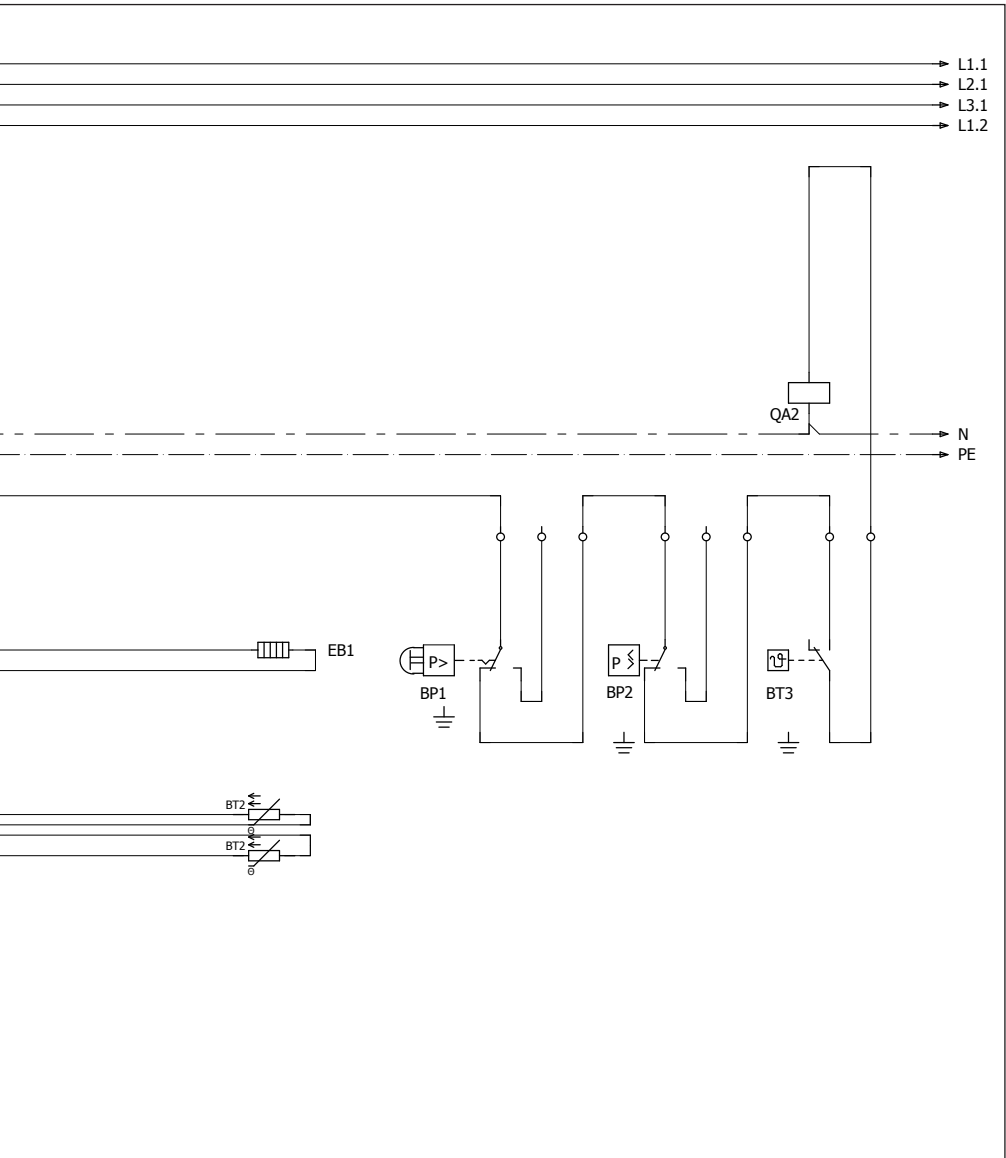

Fig. 14

BT1	Cold conductor (PTC sensor) motor winding
BT2	Thermal protection thermostat (PTC sensor)
FC1	Load circuit safety switches
FC2	Control power circuit fuse
BP1	High pressure safety monitor
BP2	Safety chain (high/low pressure monitoring)
BT3	Release switch (thermostat/pressostat)



GB

QA1	Main switch
SF1	Control voltage switch
EC1	Compressor motor
QA2	Compressor contactor
INT69 G	Electronic trigger unit INT69 G
EB1	Oil sump heater

5| Electrical connection

5.4 Electronic trigger unit INT69 G

The compressor motor is fitted with cold conductor temperature sensors (PTC) connected to the electronic trigger unit INT69 G in the terminal box. In case of excess temperature in the motor winding, the INT69 G deactivates the motor contactor. Once cooled, it can be restarted only if the electronic lock of the output relay (terminals B1+B2) is released by interrupting the supply voltage.

The hot gas side of the compressor can also be protected against overtemperature using thermal protection thermostats (accessory).

The unit trips when an overload or inadmissible operating conditions occur. Find and remedy the cause.



INFO

The relay switching output is executed as a floating changeover contact. This electrical circuit operates according to the quiescent current principle, i.e. the relay drops into the idle position and deactivates the motor contactor even in case of a sensor break or open circuit.

5.5 Connection of the trigger unit INT69 G



INFO

Connect the trigger unit INT69 G in accordance with the circuit diagram. Protect the trigger unit with a delayed-action fuse (FC2) of max. 4 A. In order to guarantee the protection function, install the trigger unit as the first element in the control power circuit.



ATTENTION Measure circuit BT1 and BT2 (PTC sensor) must not come into contact with external voltage.

This would destroy the trigger unit INT69 G and PTC sensors.

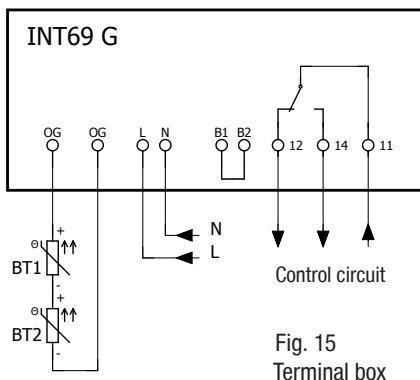

5.6 Function test of the trigger unit INT69 G

Before commissioning, after troubleshooting or making changes to the control power circuit, check the functionality of the trigger unit. Perform this check using a continuity tester or gauge.

5| Electrical connection

	Gauge state	Relay position
1.	Deactivated state	11-12
2.	INT69 G switch-on	11-14
3.	Remove PTC connector	11-12
4.	Insert PTC connector	11-12
5.	Reset after mains on	11-14

Relay position INT69 G

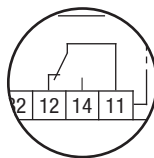

Fig. 16

5.7 Oil sump heater

In order to avoid damage to the compressor, the compressor is equipped with an oil sump heater as a standard feature.



ATTENTION The oil sump heater must generally be connected and operated!

Operation: The oil sump heater operates when the compressor is at a standstill. When the compressor starts up, the oil sump heating switches off.

Connection: The oil sump heater must be connected via an auxiliary contact (or parallel wired auxiliary contact) of the compressor contactor to a separate electric circuit.

Electrical data: 220 - 240 V - 1 - 50/60 Hz, 80 W.

5.8 Selection and operation of compressors with frequency converters

For safe operation of the compressor, the frequency converter must be able to apply an overload of at least 160% of the compressor's maximum current (I-max.) for at least 3 seconds.

When using frequency converters, the following things must also be observed:

1. The maximum permissible operating current of the compressor (I-max) (see type plate or technical data) must not be exceeded.
2. If abnormal vibrations occur in the system, the affected frequency ranges in the frequency converter must be blanked out accordingly.
3. The maximum output current of the frequency converter must be greater than the maximum current of the compressor (I-max).
4. After each compressor start, run for at least 1 minute at a frequency of at least 50 Hz.
5. Carry out all designs and installations in accordance with the local safety regulations and common rules (e.g. VDE) and regulations as well as in accordance with the specifications of the frequency converter manufacturer

The permissible frequency range can be found in the technical data.

For compressors with LSPM motors, operation with frequency converter is only recommended in delta connection with corner point of the V/f curve 230 V/50 Hz. This ensures that during operation of the compressor, within the permissible frequency band and application limits, the motor does not fall into its asynchronous state due to undervoltage/field weakening operation. For start-up and low speed operation, a voltage boost of 10-20V is recommended to slightly reduce the motor current and compensate for voltage drops through the compressor supply line (and filtering devices, if present).

5 | Electrical connection

Rotational speed range	0 - f-min	f-min - f-max
Start-up time	< 1 s	ca. 4 s
Switch-off time	immediately	

f-min/f-max see chapter: Technical data: adjustable frequency range

6 | Commissioning

6.1 Preparations for start-up



INFO

In order to protect the compressor against inadmissible operating conditions, high-pressure and low-pressure pressostats controls are mandatory on the installation side.

GB

The compressor has undergone trials in the factory and all functions have been tested. There are therefore no special running-in instructions.

Check the compressor for transport damage!



WARNING

When the compressor is not running, depending on ambient temperature and amount of refrigerant charge, it is possible that the pressure may rise and exceed permitted levels for the compressor. Adequate precautions must be taken to prevent this happening (e.g. using a cold storage medium, a receiver tank, a secondary refrigerant system, or pressure relief devices).

6.2 Pressure strength test

The compressor has been tested in the factory for pressure integrity. If however the entire system is to be subjected to a pressure integrity test, this should be carried out in accordance with EN 378-2 or a corresponding safety standard **without the inclusion of the compressor**.

6.3 Leak test



DANGER

Risk of bursting!

The compressor must only be pressurised using nitrogen (N₂). Never pressurise with oxygen or other gases!

The maximum permissible overpressure of the compressor must not be exceeded at any time during the testing process (see name plate data)! Do not mix any refrigerant with the nitrogen as this could cause the ignition limit to shift into the critical range.

6 | Commissioning

- Carry out the leak test on the refrigerating plant in accordance with EN 378-2 or a corresponding safety standard, while always observing the maximum permissible overpressure for the compressor.

Only dry test gases may be used for the leak test, e.g. nitrogen N₂ min. 4.6 (= purity 99.996 % or higher).

6.4 Evacuation



ATTENTION Do not start the compressor if it is under vacuum. Do not apply any voltage - even for test purposes (must only be operated with refrigerant).

Under vacuum, the spark-over and creepage current distances of the terminal board connection bolts shorten; this can result in winding and terminal board damage.

- First evacuate the **system** and then include **the compressor in the evacuation process**.
- Relieve the compressor pressure.
- Open the suction and pressure line shut-off valves.
- Turn on the oil sump heater.
- Evacuate the suction and discharge pressure sides using the vacuum pump.
- The vacuum has to be broken with nitrogen several times between the evacuation.
- At the end of the evacuation process, the vacuum should be < 1.5 mbar when the pump is switched off.
- Repeat this process as often as is required.

GB

6.5 Refrigerant charge



CAUTION Wear personal protective clothing such as goggles and protective gloves!

- Make sure that the suction and pressure line shut-off valves are open.



INFO Depending upon design of the CO₂ refrigerant filling bottle (with/without tubing) CO₂ can be filled in liquid after weight or gaseously.

Use only high-dried CO₂ quality (see chapter 3.1)!

- **Filling the liquid refrigerant:** It is recommended that the system first be filled at standstill with gas on the high-pressure side up to a system pressure of at least 5.2 bar (if it is filled below 5.2 bar with liquid, there is a risk of dry ice formation). Further filling according to system.

To eliminate the possibility of dry ice formation when the system is operating (during and after the filling process), the shut-off point of the low-pressure switch should be set to a value of at least 5.2 bar.



WARNING Never exceed the max. permissible pressures while charging. Precautions must be taken in time.

6 | Commissioning

- A refrigerant supplement, which may become necessary after start-up, can be topped up in vapour form on the suction side.



- ATTENTION**
- Avoid overfilling the machine with refrigerant!
 - Do not charge liquid refrigerant into the suction-side on the compressor.
 - Do not mix additives with the oil and refrigerant.

6.6 Start-up



- WARNING** Ensure that both shut-off valves are open before starting the compressor!

- Check that the safety and protection devices (pressure switch, motor protection, electrical contact protection measures, etc.) are functioning properly.
- Switch on the compressor and let it run for at least 1 minute at a frequency of at least 50 Hz. Only then may the speed of the compressor be reduced.
- The machine should reach a state of equilibrium.
- Check the **oil level**: The oil level must be visible in the sight glass.
- After a compressor is replaced, the oil level must be checked again. If the level is too high, oil must be drained off (danger of oil liquid shocks; reduced capacity of the refrigerating system).



- ATTENTION** If larger quantities of oil have to be topped up, there is a risk of oil impact effects. If this is the case, check the oil return!

6.7 Pressure switch

Suitably adjusted pressure switches according to EN 378 that switch off the compressor **before reaching** the maximum permissible operating pressure must be installed in the system. The pressure reduction for the pressure switches can occur either at the suction and pressure lines between the shut-off valve and compressor or at the non-lockable connections for the shut-off valves (connections A and B, see Chapter 9).

6 | Commissioning

6.8 Decompression valves



ATTENTION The compressor is fitted with two decompression valves. One valve each on the suction and discharge side. If excessive pressures are reached, the valves open and prevent further pressure increase.

Thereby CO₂ is blown off to the ambient!

In the event that a pressure relief valve activates repeatedly, check valve and replace if necessary as during blow-off extreme conditions can occur, which may result in a permanent leak. Always check system for refrigerant loss after activation of pressure relief valve!

The decompression valves do not replace any pressure switches and the additional safety valves in the system. Pressure switches must always be installed in the system and designed or adjusted in accordance with EN 378-2 or appropriate safety standards.

Failure to observe can result in risk of injury from CO₂ streaming out of the two decompression valves!

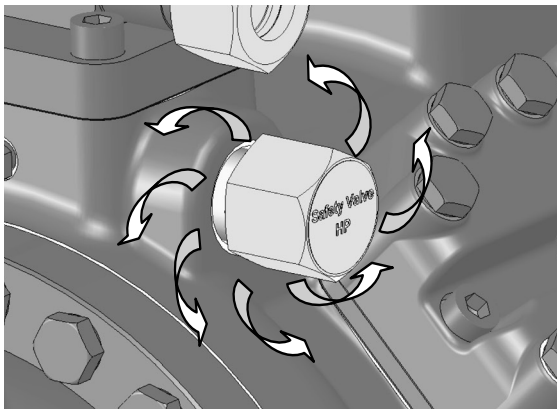

CO₂ streaming out

Fig. 17

GB

6 | Commissioning

6.9 Avoiding slugging



ATTENTION Slugging can result in damage to the compressor and cause refrigerant to leak.

To prevent slugging:

- The complete refrigeration plant must be properly designed.
- All components must be compatibly rated with each other with regard to output (particularly the evaporator and expansion valves).
- Suction gas superheating at the compressor input **should be > 10 K** (check the setting of the expansion valve).
- Regard oil temperature and pressure gas temperature. (The pressure gas temperature has to be high enough min. 50 °C, so the oil temperature is > 30 °C).
- The system must reach a state of equilibrium.
- Particularly in critical systems (e.g. several evaporator points), measures such as the use of liquid traps, solenoid valve in the liquid line, etc. are recommended.

There should be no movement of refrigerant in the compressor while the system is at a standstill.

The use of a check valve is strongly recommended, especially for heat pump applications. Otherwise there is a risk of back condensation, which can cause compressor damage.

GB

6.10 Filter dryer

Gaseous CO₂ has a significantly lower solubility in water than other refrigerants. At low temperatures it can therefore cause blocking of valves and filters due to ice or hydrate. For this reason we recommend the use of an adequately sized filter drier and a sight glass with a moisture indicator.

7 | Maintenance

7.1 Preparation



WARNING Before starting any work on the compressor:

- Switch off the compressor and secure it to prevent a restart.
- Relieve compressor of system pressure.
- Prevent air from infiltrating the system!

After maintenance has been performed:

- Connect safety switch.
- Evacuate compressor.
- Release switch-on lock.



WARNING The decompression has to be carried out in a way that no dry ice respectively solid CO₂ is produced which blocks the outlet and could hinder the streaming out of CO₂. Otherwise, there is the danger that pressure can be built up again.

7 | Maintenance



DANGER



Compressors with the designation P in the marking (e.g. HGX34/290 SP 35 CO₂ T) are equipped with an LSPM motor. After opening the compressor, there is a danger for people with pacemakers or similar devices as well as metallic implants due to a considerable magnetic field. A minimum distance of 50 cm from the compressor motor must be maintained.

Cards with magnetic stripes (e.g. credit cards), mobile phones or wristwatches can also be damaged.

Electrical voltage by induction! The motor must not be turned when the terminal box is open.

As long as the compressor is closed, no magnetic field emanates from it.

7.2 Work to be carried out

In order to guarantee optimum operational reliability and service life of the compressor, **we recommend** carrying out servicing and inspection work at regular intervals:

● Oil change:

- not mandatory for factory-produced series systems.
- for field installations or when operating near the application limit: for the first time after 100 to 200 operating hours, then approx. every 3 years or 10,000 - 12,000 operating hours. Dispose of used oil according to the regulations; observe national regulations.

- **Annual checks:** Oil level, leak tightness, running noises, pressures, temperatures, function of auxiliary devices such as oil sump heater, pressure switch.

7.3 Spare part recommendation

Available spare parts and accessories can be found on our compressor selection tool under vap.bock.de as well as at bockshop.bock.de.

Only use genuine Bock spare parts!

7.4 Lubricants / oil

For operation with CO₂ the following oil types are necessary:

- | | |
|---|---------------------|
| compressor version ML(P) and S(P) : | BOCK lub E85 |
| compressor version SH(P) : | BOCK C170E |

7.5 Decommissioning

Close the shut-off valves on the compressor. CO₂ does not need to be recycled and can therefore be blown off into the environment. It is essential to ensure good ventilation or conduct the CO₂ into the outdoors to avoid danger of suffocation. When releasing CO₂, avoid a fast drop in pressure to prevent oil from exiting with it. If the compressor is unpressurized, remove the piping on the pressure- and suction-side (e.g. dismantling of the shut-off valve, etc.) and remove the compressor using an appropriate hoist. Dispose of the oil inside in accordance with the applicable national regulations.

When decommissioning the compressor (eg. for service or replacement of the compressor) larger amounts of CO₂ in the oil can be set free. If the decompression of the compressor is not sufficient enough, closed shut-off valves may lead to intolerable excessive pressure. For this reason the suction side (LP) and the high pressure side (HP) of the compressor have to be secured by decompression valves.

8 | Technical data

Type	No. of cylinders	Displacement (1450 / 1740 rpm) 50 / 60 Hz m ³ /h	Electrical data			Weight	Connections	Oil charge (sight glass centre) Ltr.
			Voltage ①	Max. operating current ② Δ / Y A	Max. power consumption ② kW			
HGX24/ 35-4 S CO ₂ T	4	3,0 / 3,6	220-240 V Δ / 380-420 V Y - 3 - 50 Hz 265-290 V Δ / 440-480 V Y - 3 - 60 Hz	15,4 / 8,9	5,1	112	④ mm (inch)	1,3
55-4 ML CO ₂ T	4	4,6 / 5,5	220-240 V Δ / 380-420 V Y - 3 - 50 Hz 265-290 V Δ / 440-480 V Y - 3 - 60 Hz	19,5 / 11,3	8,3	112	④ mm (inch)	1,5
55-4 S CO ₂ T	4	4,6 / 5,5	220-240 V Δ / 380-420 V Y - 3 - 50 Hz 265-290 V Δ / 440-480 V Y - 3 - 60 Hz	24,8 / 14,3	9,9	116	④ mm (inch)	1,3
55-4 SH CO ₂ T	4	6,0 / 7,2	220-240 V Δ / 380-420 V Y - 3 - 50 Hz 265-290 V Δ / 440-480 V Y - 3 - 60 Hz	24,9 / 14,4	9,9	116	④ mm (inch)	1,3
70-4 ML CO ₂ T	4	6,0 / 7,2	220-240 V Δ / 380-420 V Y - 3 - 50 Hz 265-290 V Δ / 440-480 V Y - 3 - 60 Hz	24,3 / 14,0	10,4	112	④ mm (inch)	1,3
70-4 S CO ₂ T	4	7,6 / 9,1	220-240 V Δ / 380-420 V Y - 3 - 50 Hz 265-290 V Δ / 440-480 V Y - 3 - 60 Hz	30,4 / 17,5	12,6	116	④ mm (inch)	1,3
70-4 SH CO ₂ T	4	9,4 / 11,3	220-240 V Δ / 380-420 V Y - 3 - 50 Hz 265-290 V Δ / 440-480 V Y - 3 - 60 Hz	31,1 / 18,0	13,0	116	④ mm (inch)	1,3
90-4 ML CO ₂ T	4	7,6 / 9,1	220-240 V Δ / 380-420 V Y - 3 - 50 Hz 265-290 V Δ / 440-480 V Y - 3 - 60 Hz	32,4 / 18,7	13,6	116	④ mm (inch)	1,3
90-4 S CO ₂ T	4	9,4 / 11,3	220-240 V Δ / 380-420 V Y - 3 - 50 Hz 265-290 V Δ / 440-480 V Y - 3 - 60 Hz	38,4 / 22,2	16,3	116	④ mm (inch)	1,3
90-4 SH CO ₂ T	4	9,4 / 11,3	220-240 V Δ / 380-420 V Y - 3 - 50 Hz 265-290 V Δ / 440-480 V Y - 3 - 60 Hz	38,7 / 22,3	16,5	116	④ mm (inch)	1,3
110-4 ML CO ₂ T	4	9,4 / 11,3	220-240 V Δ / 380-420 V Y - 3 - 50 Hz 265-290 V Δ / 440-480 V Y - 3 - 60 Hz	38,1 / 22,0	16,2	115	④ mm (inch)	1,3
110-4 S CO ₂ T	4	9,4 / 11,3	220-240 V Δ / 380-420 V Y - 3 - 50 Hz 265-290 V Δ / 440-480 V Y - 3 - 60 Hz	46,9 / 27,1	20,1	116	④ mm (inch)	1,3
110-4 SH CO ₂ T	4	9,4 / 11,3	220-240 V Δ / 380-420 V Y - 3 - 50 Hz 265-290 V Δ / 440-480 V Y - 3 - 60 Hz	47,2 / 27,2	20,2	116	④ mm (inch)	1,3

GB

8 | Technical data

- ① Tolerance ($\pm 10\%$) relative to the mean value of the voltage range.
Other voltages and types of current on request.
- ② These are preliminary values and can differ from the actual values!
 - The specifications for max. power consumption apply for 50 Hz operation.
For 60 Hz operation, the specifications have to be multiplied by the factor 1.2.
 - The max. working current remains unchanged.
 - Take account of the max. operating current / max. power consumption for design of fuses, supply lines and safety devices. Fuse: Consumption category AC3
- ③ All specifications are based on the average of the voltage range.
For operation with frequency converter see chapter 5.8
- ④ Cutting ring connector for steel pipes and for soldered/welded joints
- ⑤ Soldered/welded joints

8 | Technical data

Type	HGX24/	Displacement (1500 / 1800 rpm)		No. of cylinders	Electrical data ③					Weight	Connections		Oil charge (sight glass centre)	Oil charge (ex works)					
		50 / 60 Hz	m ³ /h		Max. operating current ②	Max. power consumption ②	Starting current (rotor locked) ②	permissible frequency range	Discharge line DV ④		Suction line SV ⑤	kg			mm (inch)	Ltr.	Ltr.		
		Δ / Y	A	A	kW	Δ / Y	A	Hz	mm (inch)	mm (inch)	kg	Ltr.	Ltr.						
55 MLP 6 CO ₂ T		19,5 / 11,3	6,8	111 / 64	6,8	111 / 64	112	30 - 70	22 (⁷ / ₈)	19 (³ / ₄)	116	1,3							
55 SP 7 CO ₂ T		24,8 / 14,3	8,2	169 / 98	8,2	169 / 98	116												
55 SHP 7 CO ₂ T		24,9 / 14,4	8,2	169 / 98	8,2	169 / 98	116												
70 MLP 7 CO ₂ T		24,3 / 14,0	8,6	111 / 64	8,6	111 / 64	112												
70 SP 9 CO ₂ T		30,4 / 17,5	10,4	169 / 98	10,4	169 / 98	116												
70 SHP 9 CO ₂ T		31,1 / 18,0	10,7	169 / 98	10,7	169 / 98	116												
90 MLP 8 CO ₂ T		32,4 / 18,7	11,2	169 / 98	11,2	169 / 98	116												
90 SP 12 CO ₂ T		38,4 / 22,2	13,5	169 / 98	13,5	169 / 98	116												
90 SHP 12 CO ₂ T		38,7 / 22,3	13,6	169 / 98	13,6	169 / 98	116												
110 MLP 10 CO ₂ T		38,1 / 22,0	13,4	169 / 98	13,4	169 / 98	115												
110 SP 15 CO ₂ T		46,9 / 27,1	16,6	178 / 103	16,6	178 / 103	116												
110 SHP 15 CO ₂ T		47,2 / 27,2	16,7	178 / 103	16,7	178 / 103	116												

GB

8 | Technical data

- ① Tolerance ($\pm 10\%$) relative to the mean value of the voltage range.
Other voltages and types of current on request.
- ② These are preliminary values and can differ from the actual values!
 - The specifications for max. power consumption apply for 50 Hz operation.
For 60 Hz operation, the specifications have to be multiplied by the factor 1.2.
 - The max. working current remains unchanged.
 - Take account of the max. operating current / max. power consumption for design of fuses, supply lines and safety devices. Fuse: Consumption category AC3
- ③ All specifications are based on the average of the voltage range.
For operation with frequency converter see chapter 5.8
- ④ Cutting ring connector for steel pipes and for soldered/welded joints
- ⑤ Soldered/welded joints

9 | Dimensions and connections

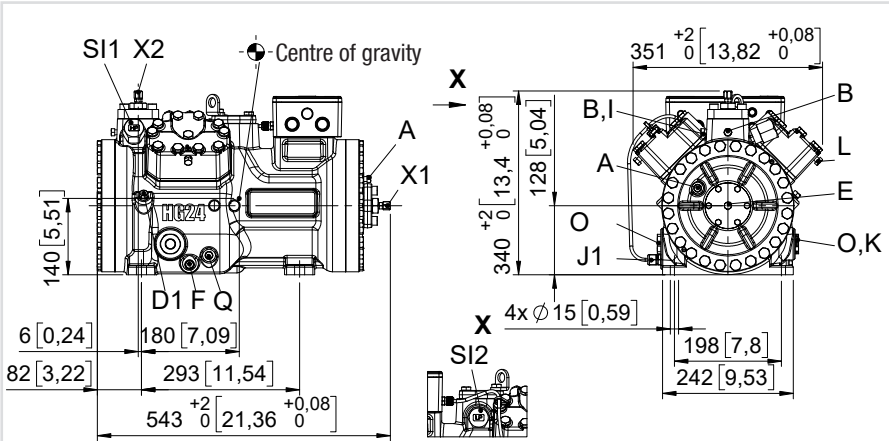

Dimensions and connections with shut-off valves:

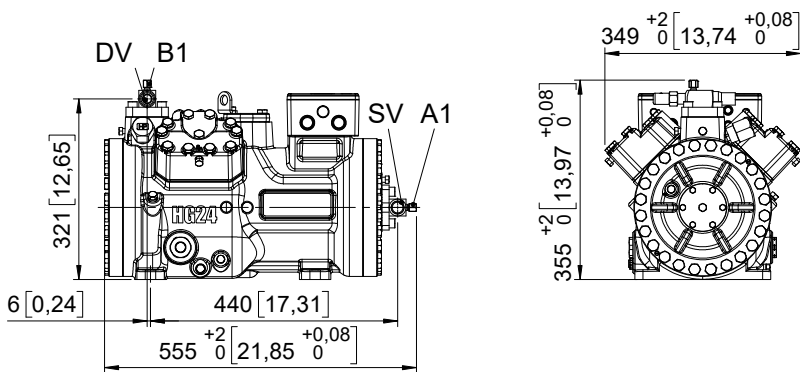

Dimensions in mm [inch]
Fig. 18

9 | Dimensions and connections

SV	Suction line	
DV	Discharge line	see technical data, chapter 8
A	Connection suction side, not lockable	1/8" NPTF
A1	Connection suction side, lockable	7/16" UNF
B	Connection discharge side, not lockable	1/8" NPTF
B1	Connection discharge side, lockable	7/16" UNF
D1	Connection oil return from oil separator	1/4" NPTF
E	Connection oil pressure gauge	1/8" NPTF
F	Oil drain	M12x1,5
I	Connection hot gas temperature sensor	1/8" NPTF
J1	Oil sump heater	3/8" NPTF
K	Sight glass	1 1/8" - 18 UNEF
L	Connection thermal protection thermostat	1/8" NPTF
O	Connection oil level regulator	2 x 1 1/8" - 18 UNEF
Q	Connection oil temperature sensor	1/8" NPTF
SI1	Decompression valve HP	M24x1,5
SI2	Decompression valve LP	M22x1,5
X1	Connection for Schrader valve, suction side	7/16" UNF
X2	Connection for Schrader valve, discharge side	7/16" UNF

GB

10 | Declaration of incorporation

Declaration of incorporation for incomplete machinery in accordance with EC Machinery Directive 2006/42/EC, Annex II 1. B

Manufacturer: Bock GmbH
Benzstraße 7
72636 Frickenhausen, Germany

We, as manufacturer, declare in sole responsibility that the incomplete machinery

Name: Semi-hermetic compressor
Types: HG(X)12P/60-4 S (HC) HG(X)88e/3235-4(S) (HC)
UL-HGX12P/60 S 0,7 UL-HGX66e/2070 S 60
HGX12P/60 S 0,7 LG HGX88e/3235 (ML/S) 95 LG
HG(X)22(P)(e)/125-4 A HG(X)34(P)(e)/380-4 (S) A
HGX34(P)(e)/255-2 (A) HGX34(P)(e)/380-2 (A)(K)
HA(X)12P/60-4 HA(X)6/1410-4
HAX22e/125 LT 2 LG HAX44e/665 LT 14 LG
HGX12e/20-4 (ML/S) CO₂ (LT) HGX44e/565-4 S CO₂
UL-HGX12e/20 (S/ML) 0,7 CO₂ (LT)... UL-HGX44e/565 S 31 CO₂
HGX12/20-4 (ML/S/SH) CO₂T..... HGX46/440-4 (ML/S/SH) CO₂T
UL-HGX12/20 ML(P) 2 CO₂T..... UL-HGX46/440 ML(P) 53 CO₂T
HGZ(X)7/1620-4 HGZ(X)7/2110-4
HGZ(X)66e/1340 LT 22..... HGZ(X)66e/2070 LT 35
HRX40-2 CO₂ T H..... HRX60-2 CO₂ T H

Name: Open type compressor
Types: F(X)2 F(X)88/3235 (NH3)
FK(X)1..... FK(X)3
FK(X)20/120 (K/N/TK)..... FK(X)50/980 (K/N/TK)

Serial number: BC00000A001 – BN99999Z999

complies with the following provisions of the above-mentioned Directive:

According to Annex I, points 1.1.2, 1.1.3, 1.1.5, 1.3.2, 1.3.3, 1.3.7, 1.5.1, 1.5.2, 1.5.13 and 1.7.1 to 1.7.4 (excepted 1.7.4 f) are fulfilled.

Applied harmonised standards, in particular:

EN ISO 12100 :2010 Safety of machinery — General principles for design — Risk assessment and risk reduction
EN 12693 :2008 Refrigerating systems and heat pumps — Safety and environmental requirements — Positive displacement refrigerant compressors

Remarks: We also declare that the special technical documentation for this incomplete machine has been created in accordance with Annex VII, Part B and we obligate to provide these upon reasoned request from the individual national authorities by data transfer.

Commissioning is prohibited until it has been confirmed that the machinery into which the incomplete machine above is to be incorporated complies with the EC Machinery Directive and an EC Declaration of Conformity, Annex II. 1. A exists.

Authorized person for compiling and handing over technical documentation:

Bock GmbH
Alexander Layh
Benzstraße 7
72636 Frickenhausen, Germany

Frickenhausen, 04th of January 2021



i. A. Alexander Layh, Global Head of R&D

10 | Declaration of incorporation

Declaration of incorporation of partly completed machinery in accordance with UK Statutory Instrument Supply of Machinery (Safety) Regulations 2008, Annex II 1. B

Manufacturer: Bock GmbH
Benzstraße 7
72636 Frickenhausen, Germany



We, as manufacturer, declare in sole responsibility that the partly completed machinery

Name: Semi-hermetic compressor
Types: HG(X)12P/60-4 S (HC) HG(X)88e/3235-4(S) (HC)
UL-HGX12P/60 S 0,7 UL-HGX66e/2070 S 60
HGX12P/60 S 0,7 LG HGX88e/3235 (ML/S) 95 LG
HG(X)22(P)(e)/125-4 A HG(X)34(P)(e)/380-4 (S) A
HGX34(P)(e)/255-2 (A) HGX34(P)(e)/380-2 (A)(K)
HA(X)22e/125-4 HA(X)6/1410-4
HAX22e/125 LT 2 LG HAX44e/665 LT 14 LG
HGX12e/20-4 (ML/S) CO₂ (LT) HGX44e/565-4 S CO₂
UL-HGX12e/20 (S/ML) 0,7 CO₂ (LT)... UL-HGX44e/565 S 31 CO₂
HGX12/20-4 (ML/S/SH) CO₂T..... HGX46/440-4 (ML/S/SH) CO₂ T
UL-HGX12/20 ML(P) 2 CO₂T..... UL-HGX46/440 ML(P) 53 CO₂T
HGZ(X)7/1620-4 HGZ(X)7/2110-4
HGZ(X)66e/1340 LT 22..... HGZ(X)66e/2070 LT 35
HRX40-2 CO₂ T H..... HR(Z)X60-2 CO₂ T (H)(V)

Name: Open type compressor
Types: F(X)2 F(X)88/3235 (NH3)
FK(X)1..... FK(X)3
FK(X)20/120 (K/N/TK)..... FK(X)50/980 (K/N/TK)

Serial number: BC0000A001 – BN99999Z999

complies with the following provisions of the above-mentioned Statutory instrument:

According to Schedule 2, part1, points 1.1.2, 1.1.3, 1.1.5, 1.3.2, 1.3.3, 1.3.7, 1.5.1, 1.5.2, 1.5.13 and 1.7.1 to 1.7.4 (excepted 1.7.4 f) are fulfilled.

Designated standards: EN ISO 12100 :2010 Safety of machinery — General principles for design — Risk assessment and risk reduction
EN 12693 :2008 Refrigerating systems and heat pumps — Safety and environmental requirements — Positive displacement refrigerant compressors

Remarks: We also declare that the special technical documentation for this partly completed machine has been created in accordance with Annex II, 1. B and we obligate to provide these upon reasoned request from the individual national authorities by data transfer.

Commissioning is prohibited until it has been confirmed that the machinery into which the partly completed machine above is to be incorporated complies with the UK Statutory Instrument Supply machinery (Safety) regulations 2008 and an EC Declaration of Conformity, Annex II, 1. A exists.

Authorized person for compiling and handing over technical documentation:

Bock GmbH
Alexander Layh
Benzstraße 7
72636 Frickenhausen, Germany

Frickenhausen, 14th of October 2022

i. A. Alexander Layh, Global Head of R&D

GB

ENGINEERING
TOMORROW



Danfoss A/S

Climate Solutions • danfoss.com • +45 7488 2222

Any information, including, but not limited to information on selection of product, its application or use, product design, weight, dimensions, capacity or any other technical data in product manuals, catalogues descriptions, advertisements, etc. and whether made available in writing, orally, electronically, online or via download, shall be considered informative, and is only binding if and to the extent, explicit reference is made in a quotation or order confirmation. Danfoss cannot accept any responsibility for possible errors in catalogues, brochures, videos and other material. Danfoss reserves the right to alter its products without notice. This also applies to products ordered but not delivered provided that such alterations can be made without changes to form, fit or function of the product.
All trademarks in this material are property of Danfoss A/S or Danfoss group companies. Danfoss and the Danfoss logo are trademarks of Danfoss A/S. All rights reserved.
